

Quincaillerie du bâtiment > Charpente et toiture > Étrier de charpente >

## Etrier de charpente a ailes exterieures SEA/46/2

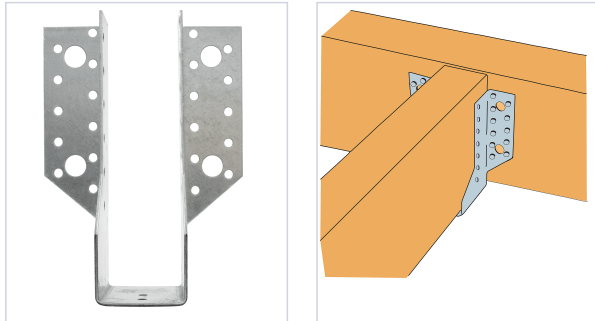
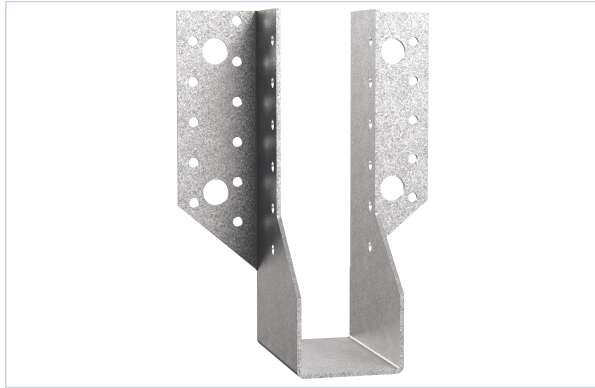

[Voir la fiche technique](#)

### Caractéristiques produit

<b>Marque</b>	Simpson
<b>Matière</b>	Acier galvanisé (S250GD + Z275)
<b>Utilisation</b>	Reprise de solives, pannes, poutres lisses et montants de bardage, butées de chevrons, renforcement d'assemblages existants.
<b>Épaisseur (mm)</b>	2
<b>Largeur (mm)</b>	46
<b>Profondeur (mm)</b>	84
<b>Secteur - Page catalogue</b>	

### Caractéristiques techniques

RÉFÉRENCE	HAUTEUR (MM)
<b>SON0265</b>	<b>77</b>



RÉFÉRENCE	HAUTEUR (MM)
<u>SON0266</u>	102
<u>SON0267</u>	147
<u>SON0268</u>	227